

LG24-12 12Volt 24Ah

Specifications

Nominal Voltage(V) **12V**

Nominal Capacity

20 hour rate	(1.2A	to	10.50V)	24Ah
5 hour rate	(4.08A	to	10.20V)	20.4Ah
1 hour rate	(13.2A	to	9.60V)	13.2Ah
1 C	(24A	to	9.60V)	12.8Ah

Weight **Approx. 9.5kg(20.9Lbs.)**

Internal Resistance (at 1KHz) **Approx. 7 mΩ**

Maximum Discharge Current for

5 seconds: **360A**

Charging Methods at 25 (77)

Cycle use:

Charging Voltage **13.8 to 14.4V**

Coefficient -5.0mv/ /cell

Maximum Charging Current : **7.2A**

Standby use:

Float Charging Voltage **13.50 to 13.80V**

Coefficient -3.0mv/ /cell

Operating Temperature Range

Charge **-15 (5) to 40 (104)**

Discharge **-15 (5) to 50 (122)**

Storage **-15 (5) to 40 (104)**

Charge Retention (shelf life) at 20 (68)

1 month **92%**

3 month **90%**

6 month **80%**

Case Material

ABS

(Option: UL94 HB & UL94 V-0 flame retardant)

Terminal

F3



Dimensions

mm(inch)

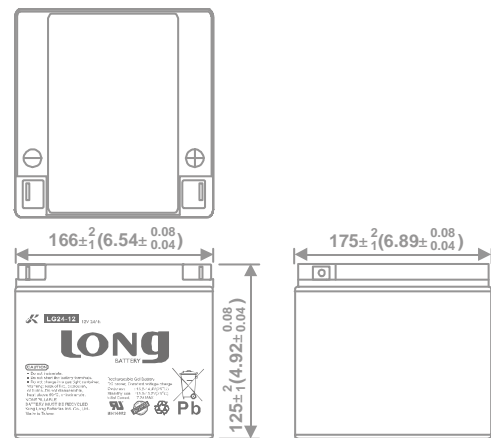
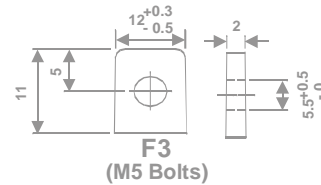

(V) Discharge Time VS. Discharge Current (25)
FOR 12V BATTERY

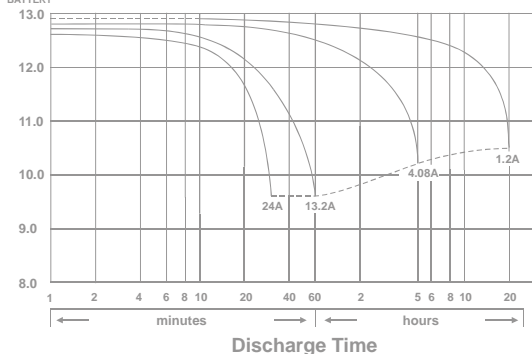

Effect of Temperature on Capacity 25 (77)

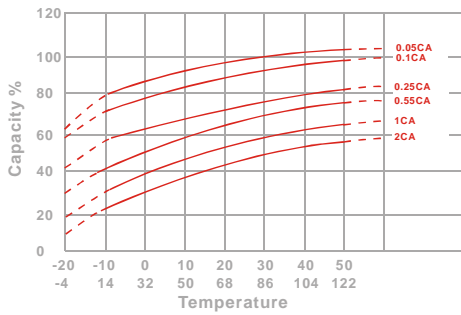

Capacity Retention Characteristic

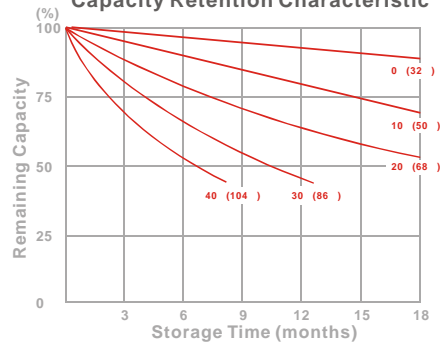

Trickle (or float) Service Life

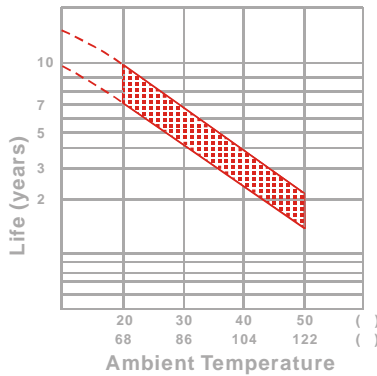

Cycle Service Life

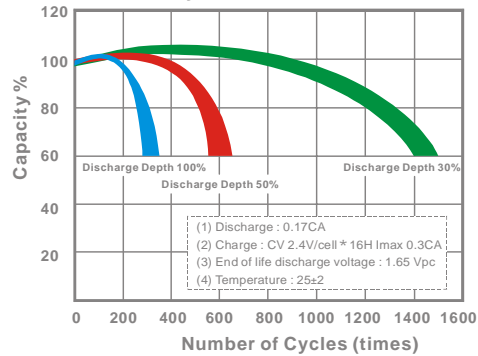

- PERFORMANCE DATA

Discharge Rates in Watts to Various End Voltages at 25 (77)

End Voltage		1.85V	1.80V	1.75V	1.70V	1.67V	1.65V	1.60V
Time								
5	min	795	903	976	1018	1030	1044	1046
10	min	547	608	637	660	687	700	731
15	min	402	463	492	520	531	541	556
30	min	213	246	271	287	291	296	302
60	min	139	153	164	173	176	179	183
120	min	92.7	100	105	109	110	112	114
180	min	69.1	73.2	75.5	77.4	78.1	78.8	79.6
240	min	56.3	59.7	61.2	62.4	62.8	63.3	63.9
300	min	48.9	51.0	51.9	52.6	52.8	53.1	53.5
600	min	27.6	29.1	30.3	31.1	31.3	31.5	31.8
1200	min	15.2	15.7	16.1	16.4	16.5	16.6	16.7

- Discharge Rates in Amperes to Various End Voltages at 25 (77)

End Voltage		1.85V	1.80V	1.75V	1.70V	1.67V	1.65V	1.60V
Time								
5	min	67.0	79.6	88.5	94.2	95.9	97.7	99.5
10	min	47.2	53.1	56.0	58.7	60.8	62.5	65.6
15	min	32.6	38.2	42.1	45.3	46.5	47.4	48.7
30	min	18.2	21.4	23.7	25.4	25.9	26.6	27.1
60	min	14.3	15.1	15.5	15.9	16.0	16.2	16.4
120	min	8.41	8.79	9.04	9.27	9.34	9.40	9.49
180	min	5.75	6.06	6.29	6.51	6.58	6.64	6.73
240	min	4.89	5.17	5.36	5.52	5.56	5.60	5.67
300	min	4.15	4.38	4.56	4.70	4.73	4.77	4.82
600	min	2.21	2.36	2.47	2.56	2.58	2.61	2.64
1200	min	1.17	1.24	1.29	1.33	1.34	1.36	1.38

All data on the spec. sheet is an average value:

The tolerance range : X<6min(+15%~-15%), 6min X<10min(+12%~-12%),10min X < 60min(+8%~-8%), X 60min(+5%~-5%)